

Operating Instructions

Photovoltaic Inverters PAC/ PAC-S

OELMAIER
Technology



Contents

	<i>Page</i>
1 General Information	3
1.1 Generation of current from solar energy - overview	3
1.2 Safety instructions	4
1.3 The inverter series PAC/ PAC-S and their additional options	5
1.4 Functional principle photovoltaic inverters PAC/ PAC-S	6
1.5 Internal protection concept	8
1.6 Scope of delivery and packing	8
2 Mounting of photovoltaic inverter PAC/ PAC-S	9
2.1 Criteria for positioning of the device	9
2.2 Mechanical dimensions	10
2.3 Mounting procedure	11
3 Interfaces of the inverter PAC/ PAC-S	13
3.1 General information	13
3.2 Connection to the public mains supply	13
3.3 Plants with several inverters	15
3.4 Connection of PV generator	17
3.5 Connection of error report	18
3.6 Data logging via RS485 interface	18
4 Initial start-up/ Operation of inverter PAC/ PAC-S	19
4.1 Initial start-up	19
4.2 Display and settings	19
4.3 Switching off/ Dismounting of inverters	22
5 Technical data of photovoltaic inverter PAC/ PAC-S	23
5.1 Electrical data DC input	23
5.2 Electrical data AC output	23
5.3 Electrical data	24
5.4 Mechanical and technical data	24
5.5 Limit values	25
5.6 Standards and regulations	26

5.7	Dimensioning of the PV generator	27
6.1	Declaration of conformity	28
6.2	Document of compliance	29
6.3	Guideline for transport damage	30
7	Error diagnostics and correction	31
7.1	Service	33
7.2	Glossary	33

Operating Instructions

Photovoltaic Inverters PAC/ PAC-S



1 General Information

1.1 Generation of current from solar energy - overview

The photovoltaic modules (PV modules) are called PV generators within the PV plant. They convert daylight into electrical energy. The direct current generated in this process is converted by means of an inverter into customary mains alternating current. This mains alternating current can be supplied into the public mains supply after having received the required authorisation by the respective energy distribution company. An export meter that is installed for this purpose registers the amount of electricity fed. Refund (credit) will be executed by your local energy distribution company.

1.2 Safety instructions

Safety symbol

In these operating instructions potential sources of danger are marked by the following symbol:

	<p>Attention</p> <p>This symbol marks hazards that may lead to severe injuries. There is also the danger of damage or destruction of hardware respectively software.</p>
---	---

Info symbol

	<p>This symbol marks helpful information</p>
---	--

Further symbols to specify sources of danger

The following symbols are normally not used in the operating instructions. They can be illustrated on the device/equipment and are there to caution against sources of danger as to high voltage and / or current respectively hot surfaces.

	<p>Caution!</p> <p>Danger of life-threatening voltage!</p> <p>Even in disconnected state the device may still provide high contact voltage!</p>
---	---

	<p>Caution!</p> <p>Hot surface!</p> <p>Do not touch. Risk of burns.</p>
---	---

Operating Instructions

Photovoltaic Inverters PAC/ PAC-S



1.3 The inverter series PAC/ PAC-S and their additional options

Type of inverter

- **PAC 2** Nominal power 2 kW
- **PAC 2S** Nominal power 2 kW

- **PAC 3** Nominal power 3 kW
- **PAC 3S** Nominal power 3 kW

- **PAC 4** Nominal power 4 kW
- **PAC 4S** Nominal power 4 kW

- **PAC 5** Nominal power 5 kW
- **PAC 5S** Nominal power 5 kW

- **PAC 7** Nominal power 7 kW

Optional

- **logPAC monitoring system for data logging**
 - logPAC 50*
 - logPAC 100*

1.4 Functional principle photovoltaic inverters PAC/ PAC-S

The functional principle of the inverter is shown in the following illustration:

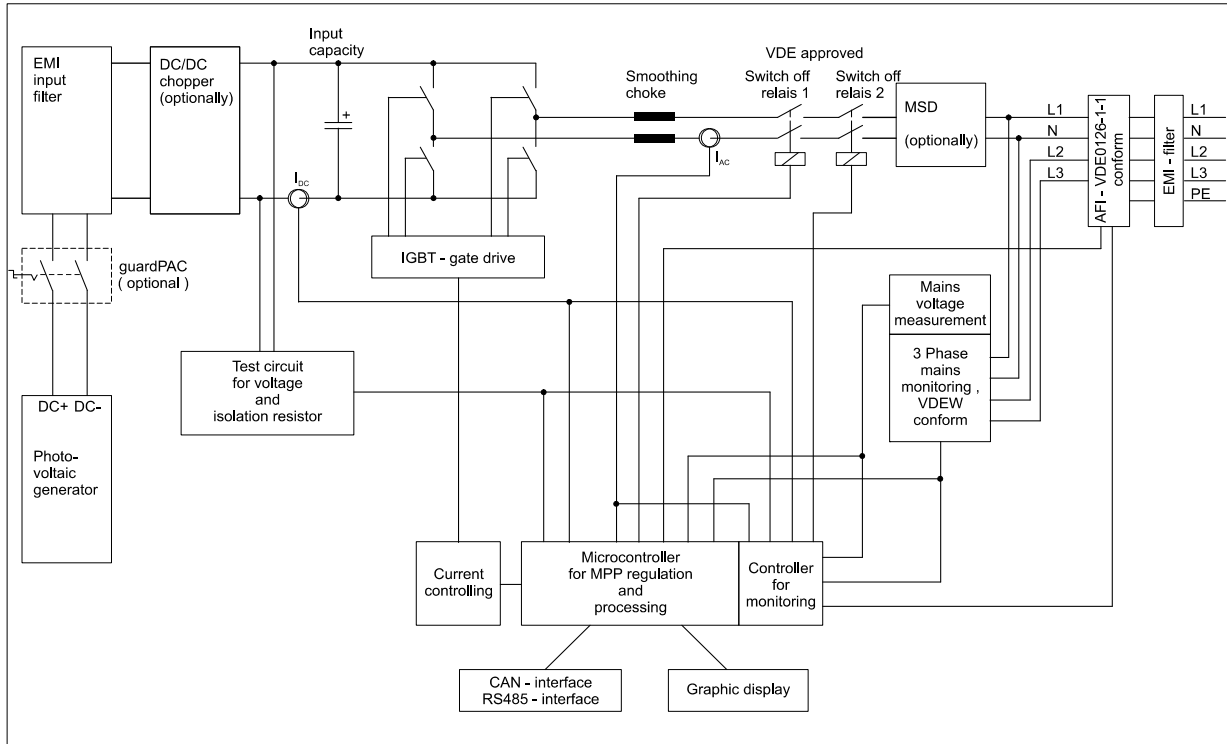

EMI Filter

Specially adjusted EMI filters are integrated in the main assembly on both input and output side. These discretely installed filters grant observation of the EMI limit values.

Input capacitance

The inverter works with an innovative MPP algorithm, which provides maximum adaptation degrees of efficiency. To provide this efficient MPP tracking generously dimensioned input capacitance on the part of the PV generator is required. On PAC the input capacitance is implemented with long-life electrolytic capacitors. These are dimensioned in way that despite the usual and normal loss in capacitance after many years of service full functional capability of the inverter system can be granted. For further increase of the reliability of the equipment it is a standard feature that electrolytic capacitors with a temperature limit of up to 105°C are installed in all PAC inverters.

IGBT full bridge (IGBT activation)

The IGBT full bridge consists of IGBT modules. A special protection circuit makes sure that the power semiconductors used are not vulnerable to failures even under extraordinary operating conditions. High quality, state-of-the-art power semiconductors provide precise inverter operation with low equipment loss. Due to a special control principle of power levels there is considerably lower capacitive leakage current in comparison with other transformerless inverter devices.

Operating Instructions

Photovoltaic Inverters PAC/ PAC-S



Smoothing chokes

By means of the feed chokes used a 100% sinusoidal feed-in current flow is produced. The special design of the chokes and the high quality core material increase the overall efficiency of the inverter.

Disconnection from supply

The used relays guarantees secure disconnection from supply when switching off at night or in case of failure. They have been inspected and approved by the VDE (German Association for Electrical, Electronic and & Information Technologies)

DC voltage and current collection

The PV generator current flows and generator voltages are collected via a corresponding connection for measurement and are prepared for further processing. These electrical values are needed for precise control of the feed-in current.

Mains monitoring

Integrated in the PV inverter is VDEW compliant 3-phase mains monitoring. Among other tasks it permanently monitors the voltage values of all three-phase conductors of the grid. In case of power failure, over-voltage or under-voltage or an upcoming grid frequency that is beyond the regulated tolerances the inverter is subjected to an **all-pole** disconnection from the grid and feed-in is interrupted. As soon as mains supply is available again or is again within stipulated limits the inverter supplies to the national grid again automatically.

For single phase Inverters: A MSD is necessary instead of a 3-phase mains monitoring. (MSD=Mains Monitoring Device)

Micro-processor controlled operation management

In this part of the equipment the processor-controlled regulation of feed-in current, all safety monitoring systems and the entire MPP control takes place. Moreover here the relevant plant data is processed and – if required - shown at the graphic display.

In addition all available data interfaces are operated from here; this means that communication with all supported and externally coupled peripheral devices is possible.

LCD Display

The serially integrated graphic display informs at any time about the current feeding status. Beside date and time the current feeding capacity, the achieved daily peak capacity and the operating hours are displayed. Further display items see chapter 4.2.

Serial Interface

Via a galvanically isolated, serial data interface (RS485) current operating data of the PV plant can be transferred to a personal computer for monitoring. To do so further accessories are needed (see options 1.3)

Standby

During the inactive time when the inverter cannot feed in due to climatic conditions (e.g. at night, missing solar radiation or darkening due to thunder clouds) all systems that are not required are switched off to make sure the inverter PAC uses a minimum of intrinsic energy.

At a generator off-load voltage of 380V or more the inverter starts feeding operation automatically.

1.5 Internal protection concept

The following monitoring and protective functions are serially integrated in the inverter PAC:

- 3-phase-mains monitoring to prevent formation of isolated networks.
- Over-voltage suppressor and further limiting systems for protection of the power semiconductors against high-energy over-voltage from the public mains supply and from the PV generator side.



No external lightning protection!

The respective lightning protection measures vary in relation to size of the plant, type of plant and local circumstances (existing lightning protective system) and have to be observed by installation personnel!

- Thermal monitoring and protection of the entire inverter system.
- EMI filter for effective suppression of EMI mains failures.
- Grid-related over-voltage protection against earth potential to protect inverter against occurring burst and surge impulses.
- All-current sensitive fault current protection switch for reliable recording of fault current in the overall PV system and to protect humans.

1.6 Scope of delivery and packing

1	unit	Inverter PAC/ PAC-S
1	unit	Documentation for mounting and operation
1	unit	Mounting bracket made of stainless steel
1	unit	Retaining bracket, stainless steel
1	unit	Protective cover for Sub-D connector
2	unit	Protective cover for DC connection (System MC 4)

The inverters PAC are dispatched in stable, shipment-friendly and eco-friendly packing.

Operating Instructions

Photovoltaic Inverters PAC/ PAC-S



2 Mounting of photovoltaic inverter PAC/ PAC-S

General Information

To achieve maximum output of the PV plant it is important to choose the right place for installation of the inverter. Excessive heating may result in reduction of the capacity or even shutdown of the inverter. (Admissible ambient temperature -20°C ... $+60^{\circ}\text{C}$). Too high humidity also has to be avoided by all means.

The inverter is designed for wall fixture whereas the following criteria have to be observed when choosing position for installation.

2.1 Criteria for positioning of the device

- Place for installation that is cool all year (e.g. cellar) is to be preferred.
- For mounting the fixing ground has to be solid and capable to bear weight. Lightweight walls are to be avoided.
- Please use – depending on nature of wall – corresponding wall plugs for fixing the mounting bracket of the inverter. For installation outdoors please use stainless steel bolts.
- For ease of operation we recommend installation at eye level (facilitates reading the display).
- For constant maximum energy yield please make sure that:
 - the inverter is not exposed to direct solar radiation and
 - is mounted with optimum ventilation from the bottom.
- The following minimum distances are to be observed:
 - Above the housing to other machinery, boards, ceiling or similar a distance of 400 mm has to be observed.
 - Under the device a distance of 150 mm to the cooling element has to be observed to achieve optimum circulation of air.
 - Lateral distance of a minimum of 100 mm has to be observed.
 - If several inverters are mounted these are to be mounted side by side.

When mounting PAC into an electric control cabinet or similar forced ventilation is required to provide sufficient heat removal.



During operation cooling element can reach a temperature of 80°C !

2.2 Mechanical dimensions

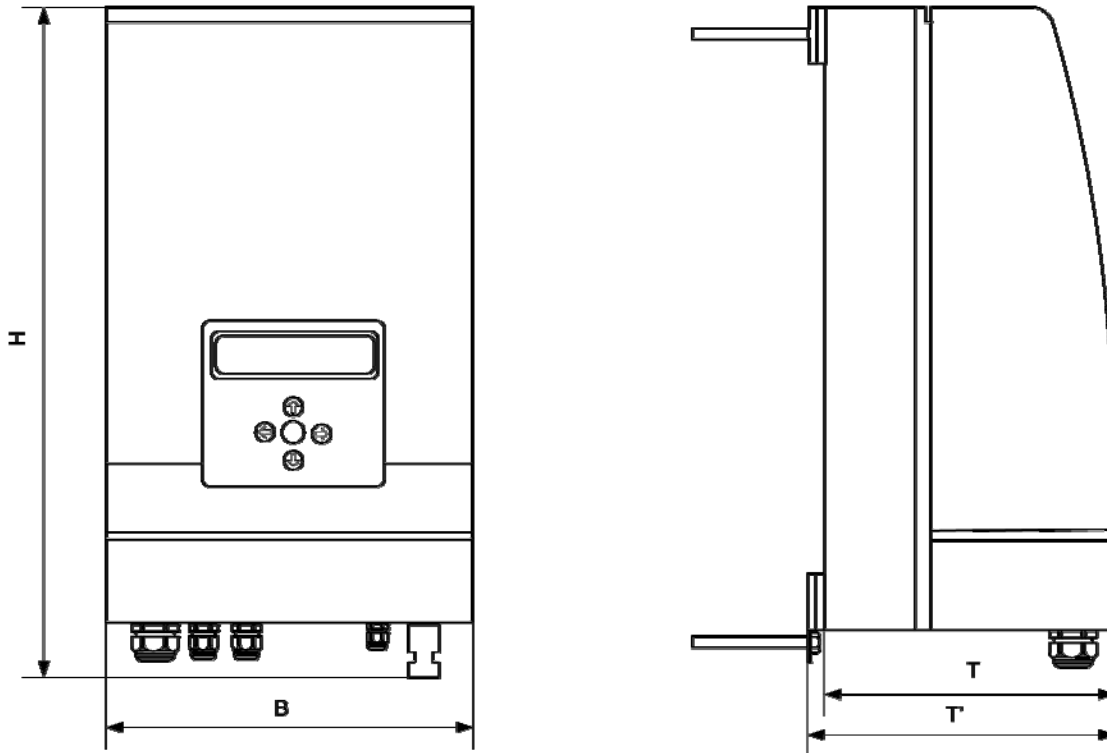

PAC	2/ 2S	3/ 3S	4/ 4S	5/ 5S	7
B x H x T	250 x 550 x 170		250 x 550 x 212		
T'	187		222		

Operating Instructions

Photovoltaic Inverters PAC/ PAC-S



2.3 Mounting procedure

Considering the „criteria for positioning of the equipment” (see item 2.1) the required drill holes can be drilled on the basis of the drilling sketch below or according to the following step-by-step instruction. Then mount the inverter PAC.



Danger of injuries in case of improper handling and use. Please observe the general safety instructions concerning handling and mounting.

To avoid injuries of your hands during transport and installation of the inverter it is indispensable to wear protective gloves. For fixing the inverter hold it at sides and at bottom.

Mounting/ Drilling sketch

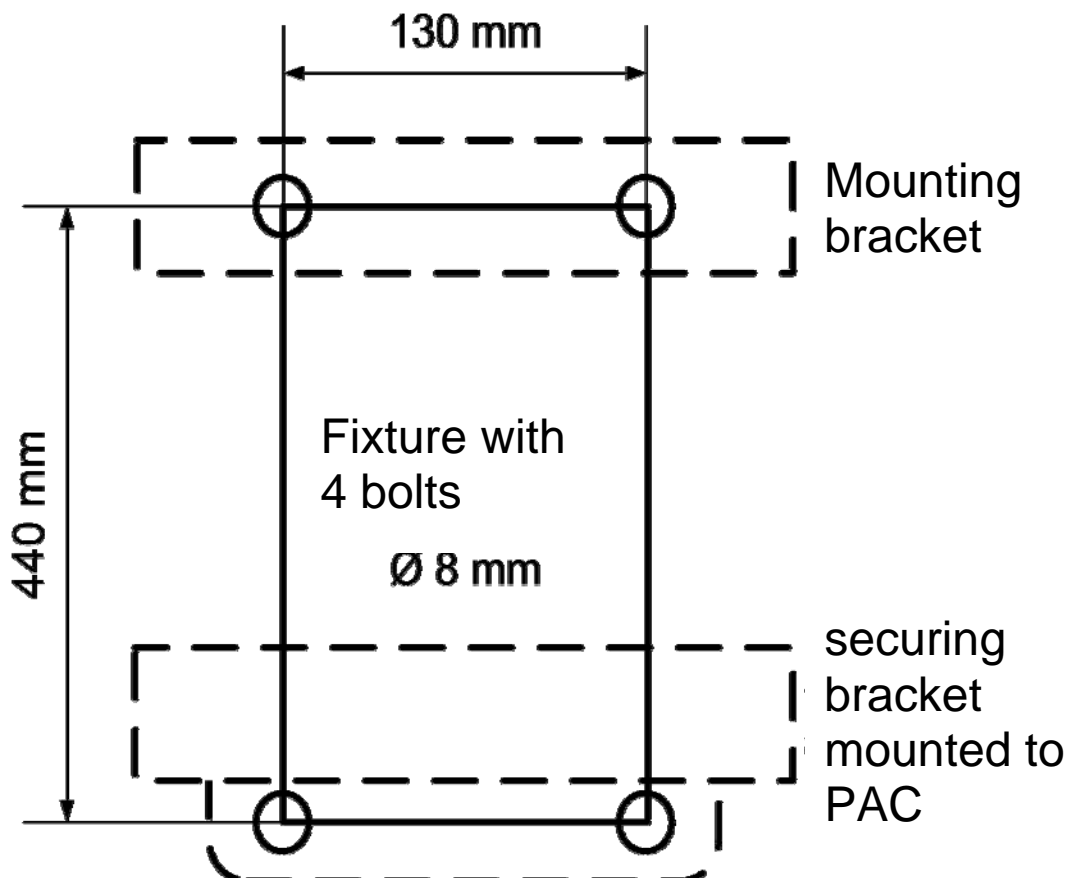

1. Level out mounting bracket at the chosen mounting position horizontally and mark the drill holes.
2. Drill corresponding holes (see drilling sketch) for wall plugs, or on wooden material for core diameter of the bolt (bolts of a minimum diameter of 8 mm); if required insert wall plugs.
- 3 Tighten the mounting bracket subsequently.
4. Fix the inverter to the existing fixing points (2 socket head bolts at cooling element, between second and third cooling fin from the outside).
- 5 Mark the drill holes for wall plugs or wood screw through the holes of the lower securing bracket and drill them. If required insert wall plugs
6. Finally fix the securing bracket at the wall. This protects the inverter against inadvertent unhinging and electrical connection can be effected.

Operating Instructions

Photovoltaic Inverters PAC/ PAC-S



3 Interfaces of the inverter PAC/ PAC-S

3.1 General information

Installation and opening of the inverters PAC is restricted to trained and qualified experts in the field of electrics.



- When working on respectively with the inverter the AC and DC circuits have to be disconnected on all poles and the discharging time of the installed capacitors (up to 30 minutes) has to be observed.
- The inverters work at high direct current voltages of up to 750V!
- Electrical connection has to be executed in compliance with the current regulations and electrical operating conditions.
- Touching live parts endangers your life!
- AC and DC circuits have to be designed for voltage, current and ambient conditions (temperature, humidity etc.) to be expected.
- Please make sure that the lines are installed safely and that any damage is avoided.
- **WARNING: HIGH LEAKAGE CURRENT!**
EARTH CONNECTION ESSENTIAL BEFORE CONNECTING SUPPLY

3.2 Connection to the public mains supply



Electrical connection to the public mains supply has to be executed by an expert in the field of electrics authorised by the relevant energy supply company.

For connection of the inverter to the public main supply 5-wire line is to be used which corresponds to the output line of the used inverter PAC. This means the cross section of the line has to be dimensioned depending on inverter current (see table below) and length of line to the point of feed-in under observation of the respective instructions for installation (see table below). For the function of 3-phase monitoring the inverter always has to get 5-core connection (3 outer conductors, neutral conductor and protective conductor).

Version "MSD": 3-wire line (outer conductor L1, neutral conductor, protective conductor)

Required protection:

PAC	2/ 2S	3/ 3S	4/ 4S	5/ 5S	7
Max. AC-current	9,5 A	14,3 A	19 A	26A	32,6A
Mains fuse	16 A	16 A	20 A	25 A	35 A

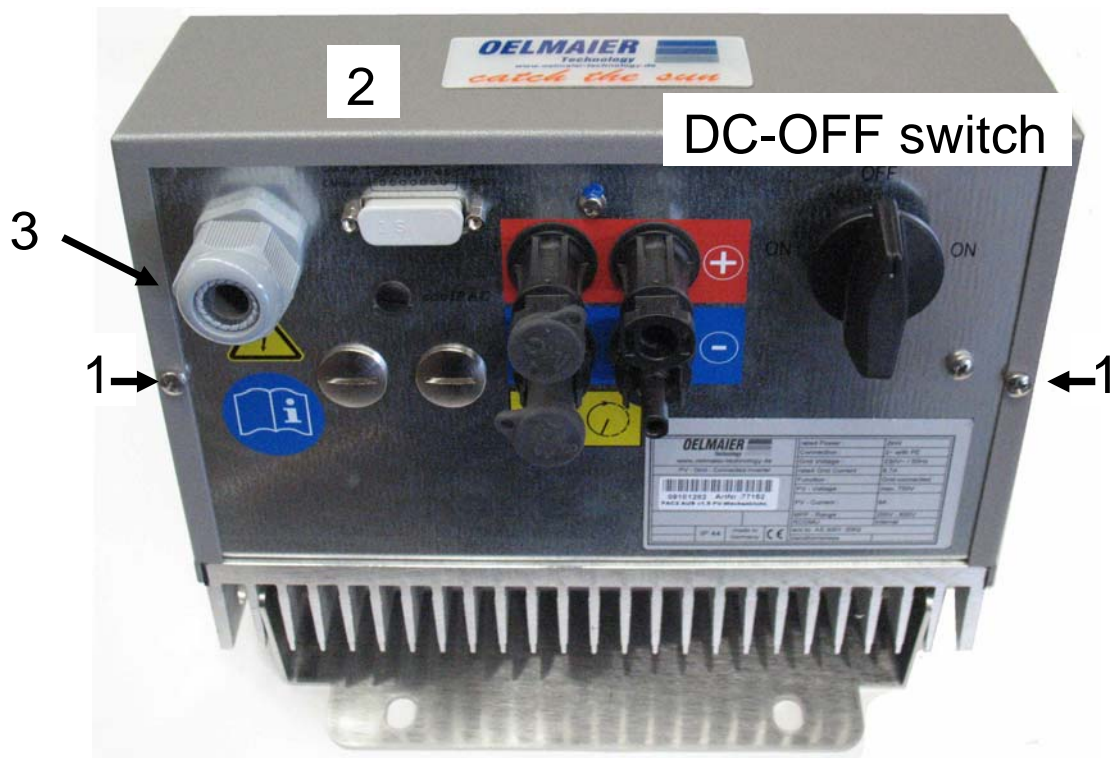

- Disconnect the mains supply and make sure before connection that it is voltage free.
- Untighten the two bolts at the outside (1) at the bottom of the inverter.
- Pull service cover (2) about 1 cm down and take it off to the front.
- Run the feeder through the cable fitting (3) into the housing and tighten the fitting.
- The individual connections are to be fixed according to terminal designation (L1/ N/ L2/ L3/ PE) at clamping block (see illustration below)

MSD-version for single phase connection: L1/ N / PE



Both the cable fitting and the mains feeder clips are designed for 5-pole cable with a wire cross section of max. 6 mm².

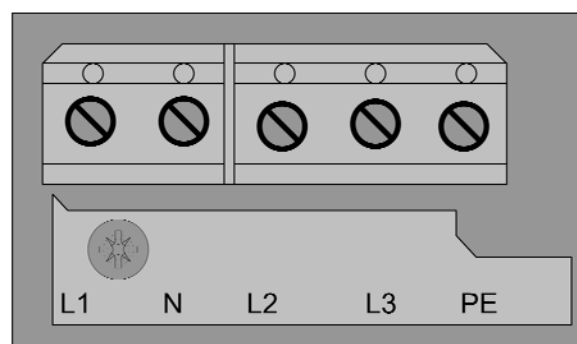

3.3 Plants with several inverters

For plants with several inverters the following points have to be observed:

Unbalanced feed-in (Germany):

If possible, the performance should be evenly distributed to the three outer conductors of the mains power supply.

According to VDEW directive (VDEW: German Association of energy supply companies) 1-2005 for connection and parallel operation of energy generating plants at the low voltage grid, unbalance **between outer conductors may not exceed a maximum of 4600 VA (for PV + 10%)!**

Electrical connection:

3-Phase monitoring:

The inverter PAC supplies to the respective outer conductor which is connected to the clamp L1. Serve the connections L2 and L3 for the compulsory 3-phase monitoring.

If several inverters are used in one PV plant please make sure that feed-in is balanced, this means that

- at the first inverter at clamp L1 outer conductor L1 has to be connected,
- at the second inverter at clamp L1 outer conductor L2 has to be connected
- at the third inverter at clamp L1 the outer conductor L3 has to be connected and so on. By doing so the output fed in is distributed in a balanced way.

Connection to grid for plants with several inverters

MSD-version:

The inverter PAC supplies to the respective outer conductor which is connected to the clamp L1.

3-Phase monitoring

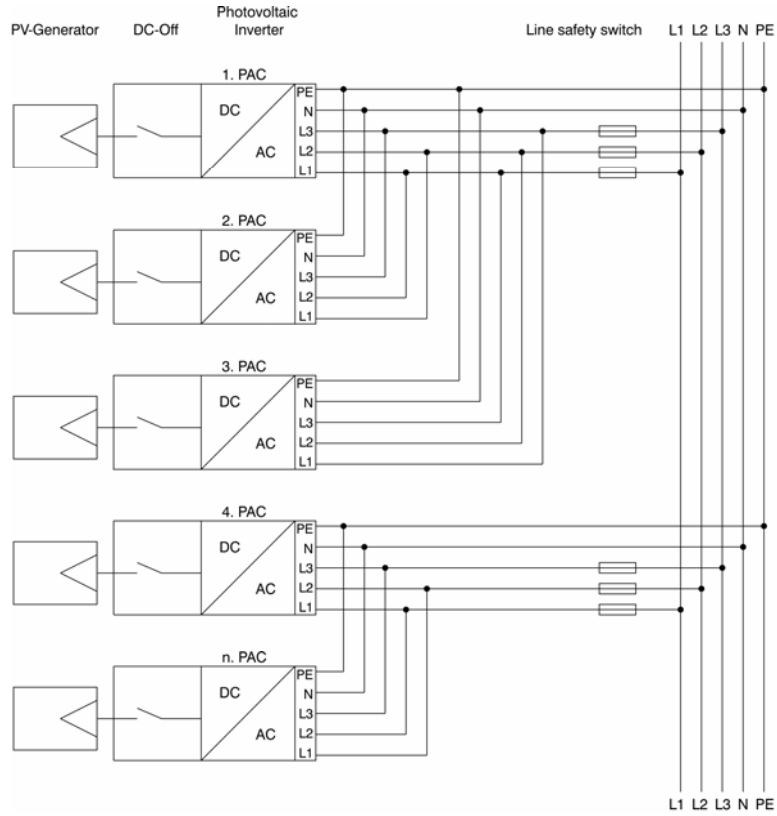

MSD-version

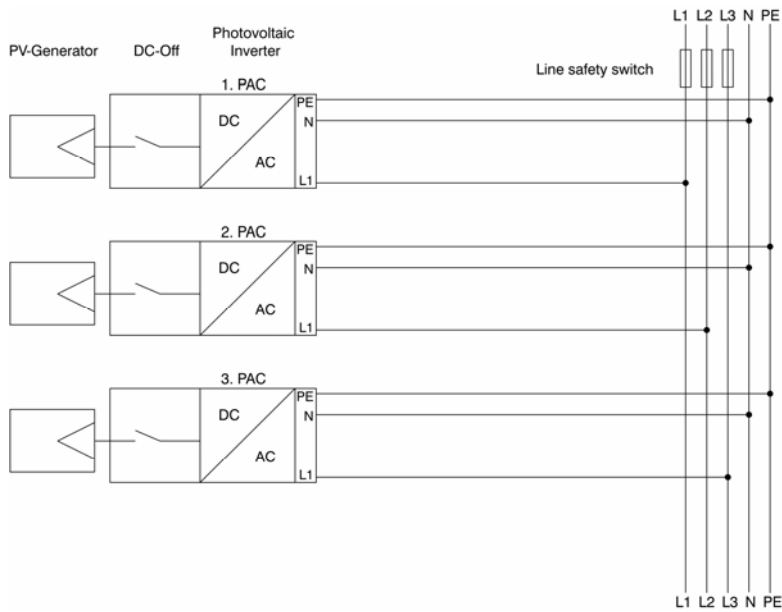

Operating Instructions

Photovoltaic Inverters PAC/ PAC-S



3.4 Connection of PV generator

The inverter PAC has to be connected via DC disconnect switch only to the PV generator (see circuit diagram in section 1.4 „Functional principle photovoltaic inverters PAC“).



Before connection the polarity of connections and DC voltage has to be measured. Please make sure that on all poles the same number of PV modules is used in the same circuitry, roof alignment and shadow conditions and therefore identical voltage conditions exist.

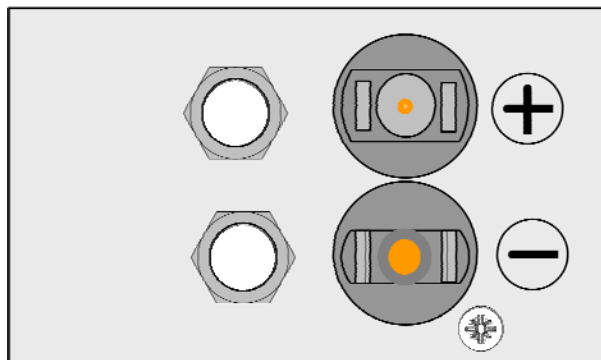

Connection of the PV generator is effected either by DC plug / coupling (system MC 4) at the bottom side of the inverter or by means of screw clamps in the interior of the device. Please observe polarity plus and minus.

Pole connections at inverter, that are not needed, have to be locked with enclosed covers.



DC plug contact may only be connected or disconnected when the inverter is connected on DC side. The same refers to operation via screw clamps.

Please check always beforehand (DC-OFF switch position „0“).

Otherwise an electric arc is produced by the high voltage; this can jeopardize your life and lead to injuries or fire.



If the PV poles do not have the same voltage they may not be interconnected, as there is a galvanic connection in the inverter and in the DC-OFF switch.



Inverse voltage!

After disconnection of the inverter from the PV generator (DC-OFF switch position „0“) capacitors in the inverter and thus also the DC connections are still energised for up to 30 minutes.

3.5 Connection of error report

On the main assembly group of the PAC there is a galvanically insulated relays contact which is designed for mains voltage of 230V AC and a maximum current load of 10 A. At this relays an optical or acoustic error report device can be connected.

If the inverter switches off due to failure the back ground illumination of the display starts to blink. At the same time the relays contact for the error report closes after a period of delay.

The following causes lead to fault reports:

(limit values for Germany!)

- Frequency fault: Alarm (signal) if frequency is $<47,5 \text{ Hz}^1$ or $> 50,2 \text{ Hz}^1$
- Excess temperature: Alarm (signal) if temperature is $> 80^\circ\text{C}$
- Overvoltage: Alarm, if mains voltage $> 265 \text{ V}^1$
- Undervoltage: Alarm, if mains voltage $< 184 \text{ V}^1$
- Phase L1, L2 or L3 missing: Alarm, as 3-phase monitoring reports „error“ or there is no operating voltage
- DC voltage too high: Alarm, if DC voltage is $> 750\text{V}$.
- Insulating resistance DC: Alarm, if resistance between DC+ or DC- towards PE is $< 1 \text{ M}\Omega$

¹ Can be adjusted to the respective applicable limit values of the relevant country, see section 5.5 Limit values

3.6 Data logging via RS485 interface

For external data logging or remote monitoring a data logger of series *logPAC* can be connected to the 15-pole SUB_D connector pin that is accessible from the outside. Up to 30 inverters and a monitoring unit can be connected to the existing Bus system.

In the service menu (installer) an address has to be allocated to each inverter. The first unit in a row has the address „01“, the second „02“, etc. On the last inverter in a row (in a bus system) the two interface jumpers on the main board (with RS 485-connecting contact) have to be plugged on contact (horizontally). Interface RS-485 (ISO 8482)

Assignment of SUB-D connector pin:

- PIN 1 R x D RS 485 - B / RS 485 -
- PIN 9 T x D RS 485 - A / RS 485 +

Operating Instructions

Photovoltaic Inverters PAC/ PAC-S



4 Initial start-up/ Operation of inverter PAC/ PAC-S



- Do not start inverter PAC before temperature of inverter has adjusted to the ambient temperature!
- Avoid condensation!



Remove protective foil from keyboard / display.

4.1 Initial start-up

After implementation of all connections, examination of firm tightening and remounting of the covers the inverter can be started up. **Should date and time not be shown correctly this has to be corrected first. (See item 4.2 setting time)**

Due to tolerances the performance values shown on the display may deviate up to 10% from the values of the export meter of your energy supply company!

1. Switch on mains voltage by connecting the line safety switch on all poles. Now you can see some information on the display.
2. Put the DC disconnect switch to „1“.

When initial off-load voltage reaches the required value of 380 Volt DC (or higher), inverter starts feeding operation automatically. The display shows current feed output (AC output).

4.2 Display and settings

The display shows in feed operation

- current performance
- daily peak performance
- daily total
- date and current time

```
AC performance: 4135 W
Daily maximum: 4870•W
Daily total:      11.35 kWh
                12.07.2008 17:51
```

1. With the key \Rightarrow you call up the dropdown menu.
2. With the keys \downarrow and \uparrow you can move the cursor $>$ and select the desired menu item.
3. By pressing the key "Enter" the chosen menu item is called up..

Dropdown menu:

```
> Output data (kWh)
Output data (EURO)
Status PV generator
Mains status
Setting language
Setting date / time
Setting refund
System information
Operating h day
```

With the key \Leftarrow you return to the dropdown menu

Display „output data (kWh)“

1. Select menu item „output data (kWh)“.
2. By pressing the key "Enter" the desired menu item is called up.

```
Output data (kWh)
Total / day:      36 kWh
W year:          2812 kWh
W total:         6756 kWh
```

With the key \Leftarrow you get back to the dropdown menu

Display „output data (EURO)“

1. Select menu item „output (EURO)“.
2. By pressing the key "Enter" the selected menu item is called up.

```
Output data (EUR)
Day:             18.50 EUR
Year:            1476.21 EUR
Total:           3472.58 EUR
```

With the key \Leftarrow you return to the dropdown menu

Display „status PV generator“

1. Select „status PV generator“.
2. By pressing the key "Enter" the selected menu item is called up.

```
Status PV generator
U DC:            456 V
I DC :           9.5 A
```

With the key \Leftarrow you return to the dropdown menu

Display „mains status“

1. Select menu item „mains status“.
2. By pressing the key "Enter" the selected menu item is called up.

```
Mains status:
U AC:   230 V    UL2: 229 V
I AC:   18 A     UL3: 233 V
F:      49.9 Hz
```

With the key \Leftarrow you return to the dropdown menu

Operating Instructions

Photovoltaic Inverters PAC/ PAC-S



Display „setting language“

1. Select menu item „setting language“ .
2. By pressing the key “Enter“ the selected menu item is called up.

```
Setting language
German?
```

3. With the keys \uparrow and \downarrow language is selected.
By pressing Enter language is stored and you return to the dropdown menu.

„Setting refund“

1. Select menu item „refund“.
2. With keys \Rightarrow and \Leftarrow you select figures for the amount
3. With keys \uparrow and \downarrow values are modified.

```
Refund / kWh
4675 / 100 Cent
```

By pressing Enter amount is stored and you return to dropdown menu.

Example: for a refund of 46.75 Cent/kWh the value 4675 has to be entered (4675/100 = 46.75 Cent).

For current refund please contact your energy supply company

Display „System information“

1. Select menu item „System information“.
2. With the key \Leftarrow you return to the dropdown menu

```
Software:
PAC 1-5 V2.7b8 svn.29.04.2008
Serial no.:
12345678
```

Display operating hours/ day

1. **Select menu item** „operating h day“
2. By pressing the key “Enter“ the selected menu item is called up

```
Operating h day:
0:00 h
```

With the key \Leftarrow you return to the dropdown menu

By actuating this key again you return to the basic setting.

4.3 Switching off/ Dismounting of inverters



To avoid injuries of your hands we recommend to wear protective gloves during dismounting and transport of the inverter.

If inverter is to be switched off for servicing please proceed as follows:

1. Disconnect mains voltage with the safety switch on all poles.
2. Disconnect direct current side (PV generator) by releasing the DC disconnect switch (switch position 0) and subsequently disconnect the multi-contact plug at the DC side.



Inverse voltage!

The used capacitors are still energised up to 30 minutes after disconnection from the PV generator!!

- 3.
4. Connection to the public mains supply“)
5. Examine if all three outer conductor have zero potential.
6. Disconnect feed line and remove it from inverter.
7. Dismount the two wall fixture bolts from the lower retaining bracket.
8. Lift inverter by about 5 cm and remove it to the front from the mounting bracket.
9. Put the inverter cautiously on the cooling element.

Operating Instructions

Photovoltaic Inverters PAC/ PAC-S



5 Technical data of photovoltaic inverter PAC/ PAC-S

5.1 Electrical data DC input

(Data for PAC-S in parenthesis)

PAC		2 / 2S	3 / 3S	4 / 4S	5 / 5S	7
DC nominal capacity	kW	2,2	3,2	4,3	4,9	7,4
MPP Range	V _{DC}	330 – 650 (200 – 600)				
Off-load voltage	V _{DC}	max 750				
Monitoring input voltage	V _{DC}	Stand-by ab U _e < 330 (< 200)				
Max. DC input current	A _{DC}	8 (11)	12 (16)	17 (22)	18 (26)	25
Surge protection		MOV passive				

5.2 Electrical data AC output

PAC		2 / 2S	3 / 3S	4 / 4S	5 / 5S	7
Nominal capacity	kW	2	3	4	4,6	7
Maximum capacity	kW	2,2	3,3	4,4	5,06	7,5
Mains voltage	V	184 ... 265 ¹				
Nominal current	A	8,7	13	17,4	20	30,4
Maximum current	A	9,5	14,3	19	22	32,6
Efficiency factor		1				
Frequency	Hz	47,5 – 50,2 ¹				
Distortion factor	%	< 3 over complete range				
Monitoring of residual current		Monitoring of the fixed limit values by all current sensitive monitoring of residual current				

¹ Can be adjusted to the respective currently valid limit values of the relevant country, see section „Limit values (as per October 2007)“

5.3 Electrical data

PAC		2 / 2S	3 / 3S	4 / 4S	5 / 5S
Maximum efficiency factor	%	96,75	96,8	96,85	96,85
European efficiency factor	%	95,42	96,02	95,94	96,05
Own consumption	W	Operation: < 8 Standby : < 3			
Minimum feed capacity	W	30			
Circuitry concept		control mains synchronous, transformerless			
Pulse frequency	kHz	17			
Principle		IGBT full bridge technology			
Mains monitoring		3-phase monitoring , VDEW-compliant as per VDE 0126-1-1/ optional MSD			

5.4 Mechanical and technical data

PAC	2 / 2S	3 / 3S	4 / 4S	5 / 5S
Optical display	Graphic display			
Operating elements	5 keys			
Connections	for mains connection, error report relays and S ₀ impulse output screw clamps inside the device with metric cable ducts, for RS 485 signal 15-pole SUB-D connector pin Multi-contact-plug (MC 4) for PV generator connections			
Ambient temperature	-20 to +70°C			
Temperature monitoring	> 74°C, temperature-dependent output adjustment > 80°C, disconnection from the grid			
Cooling	Free convection (optional: cooling system <i>coolPAC</i>)			
Protection category	IP44			
Sea level max.	2000 m			
Noise emission	< 35 dB			
Housing	Metal housing (powder-coated)			
Dimensions l x h x w	250 x 550 x 187 mm		250 x 550 x 222 mm	
Weight	approx. 21 kg		approx. 26 kg	

Operating Instructions

Photovoltaic Inverters PAC/ PAC-S



5.5 Limit values

	Voltage [V]		Frequency [Hz]		DC share (current)
	min	Max	min	Max	
Germany	184	265	47,5	50,2	1 A
Switzerland	184	265	47,5	50,2	1 A
Austria	184	265	47,5	50,2	1 A
Italy	184	276	49,7	50,3	0,5% related to P _{nenn, max}
Spain	195,5	253	49	51	1 A
France	184	265	47,5	51	1 A
Greece					
Mainland	184	265	49,5	50,5	0,5% related to P _{nenn, max}
Island	184	265	49	51	0,5% related to P _{nenn, max}
Australia	200	270	45	55	0,5% related to P _{nenn, max}

5.6 Standards and regulations

Protection category of the device: 1 (Basic insulation + PE- connection)

Protection category of the used modules : 2

VDEW Compliance

according to the Association of electric power companies "Guideline for connection and parallel operation of energy-generating plants at the low voltage grid"

Electromagnetic compatibility – requirements for household appliances, electric tools and similar apparatus.

Part1: Emission : EN55014-1

Part 2: Immunity : EN55014-2

Electromagnetic compatibility

Part 3-2 Limits - Limits for harmonic current emissions: EN61000-3-2

Teil 3-3 Limits - Limitation of voltage changes, voltage fluctuations and flicker:
EN 61000-3-3

Semiconductor converters - General requirements and line commutated converters –

Part 1-1: Specification of basic requirements EN60146-1-1

Part1-3: Transformers and reactors EN60146-1-3

Electronic equipment for use in power installation EN 50178

CE-Marking according to directive 93/68/EWG

This includes :

Low voltage directive for electrical equipment according to directive 73/23/EWG

Electromagnetic compatibility according to directive 89/336/EWG

→ IEC62 109 - 1 } Safety of power converter for use in photovoltaic power
- 2 } systems.

→ VDE 0126 – 1 -1 Independent switch point between a system-parallel
generating plant and the public low voltage grid

Operating Instructions

Photovoltaic Inverters PAC/ PAC-S



5.7 Dimensioning of the PV generator

Circuitry of the PV modules to the PV generator is of pivotal importance for the dimensioning of a PV plant. To this end our cost-free software *PACdimension* is very helpful. It serves the profit-oriented dimensioning of the inverters of Oelmaier Technology. The programme can be operated intuitively and presents results in a professional and well-arranged project report.

Please observe the following data for dimensioning of the PV generator:

(Data for PAC-S in parenthesis)

PAC	2/ 2S	3/ 3S	4/ 4S	5/ 5S	7
Max. Off-load voltage V_{OC}	$< 750V_{DC}$				
MPP voltage U_{MPP}	$330 \dots 650 (200 \dots 600) V_{DC}$				

No damage is done to the inverter PAC, if a connected PV generator provides higher power than the maximum usable input power, provided that input voltage is within the admissible input voltage range.

6. Important Information

6.1 Declaration of conformity

EG-Konformitätserklärung

Im Sinne der EMV Richtlinie 2004/108/EG, der Niederspannungsrichtlinie 2006/95/EG und der R&TTE Richtlinie

Name und Adresse der Firma

Oelmaier Technology GmbH
Kolpingstraße 2
88416 Ochsenhausen

Wir erklären in alleiniger Verantwortung, dass die Wechselrichter

PAC2 (S) und PAC 3 (S)

den Normen DIN EN 61000-6-3: 2002-08, DIN EN 61000-6-4: 2002-08, DIN EN 55022: 2003-09, Klasse B, DIN EN 61000-3-3: 2002-05; DIN EN 61000-3-2: 2001-12; DIN EN 61000-6-1: 2002-08, DIN EN 61000-6-2: 2002-08, DIN EN 50178: 1998-04 DIN EN 60146-1-1: 1994-03

sowie die Wechselrichter

PAC4 (S) und PAC5 (S)

den Normen DIN EN 61000-6-3: 2002-08, DIN EN 61000-6-4: 2002-08, DIN EN 55022: 2003-09, Klasse B, DIN EN 61000-3-3: 2002-05; DIN EN 61000-3-12: 2004-06, DIN EN 61000-6-1: 2002-08, DIN EN 61000-6-2: 2002-08, DIN EN 50178: 1998-04 DIN EN 60146-1-1: 1994-03

entsprechen und somit das CE-Zeichen erhalten.



Ochsenhausen, den 06.12.2008

Ort, Datum

Wolfgang Oelmaier / Geschäftsführer

Name und Funktion

Die EG-Konformitätserklärung verliert ihre Gültigkeit, wenn der Wechselrichter ohne unsere Zustimmung umgebaut oder verändert wird und die Aufstellhöhe von maximal 2000m ü. N.N. nicht beachtet wird.

Operating Instructions

Photovoltaic Inverters PAC/ PAC-S



6.2 Document of compliance



**BUREAU
VERITAS**

**Bureau Veritas E&E
Product Service GmbH**
Businesspark A96
86842 Türkheim
Deutschland
+ 49 (0) 8245 96810-0
info-tur@de.bureauveritas.com

Unbedenklichkeitsbescheinigung

Antragsteller: Oelmaier Technology GmbH
Kolpingstraße 2
88416 Ochsenhausen
Deutschland

Erzeugnis: Selbsttätige Schaltstelle zwischen einer netzparallelen
Eigenerzeugungsanlage und dem öffentlichen
Niederspannungsnetz

Modell: PAC2, PAC3, PAC4, PAC5
PAC2S, PAC3S, PAC4S, PAC5S

Bestimmungsgemäße Verwendung:

Selbsttätige Schaltstelle gemäß DIN V VDE V 0126-1-1:2006-02 für Photovoltaikanlagen mit Paralleleinspeisung über Wechselrichter in das Netz der öffentlichen Versorgung. Die selbsttätige Schaltstelle ist integraler Bestandteil der oben angeführten traflosen Wechselrichter. Diese dient als Ersatz für eine jederzeit dem Verteilungsnetzbetreiber (VNB) zugängliche Schaltstelle mit Trennfunktion.

Prüfgrundlagen:

DIN V VDE V 0126-1-1 (VDE V 0126-1-1):2006-02 und „Eigenerzeugungsanlagen am Niederspannungsnetz, 4. Ausgabe 2001, Richtlinie für Anschluss und Parallelbetrieb von Eigenerzeugungsanlagen am Niederspannungsnetz“ mit VDN Ergänzungen, Stand 2005 vom Verband der Elektrizitätswirtschaft (VDEW) und vom Verband der Netzbetreiber (VDN).

Ein repräsentatives Testmuster der oben genannten Erzeugnisse entspricht den zum Zeitpunkt der Ausstellung dieser Bescheinigung geltenden sicherheitstechnischen Anforderungen der aufgeführten Prüfgrundlagen für die bestimmungsgemäße Verwendung.

Bericht Nummer: 07KFS036-VDE0126

Zertifikat Nummer: U08-210

Datum: 2008-11-18

Gültig bis:

2011-10-31

Andreas Aufmuth

6.3 Guideline for transport damage

Our inverters leave our works in flawless condition as to electrics and mechanics. The packaging is adjusted to our inverters and protects them in an optimal way during transport. Nonetheless there may be damage during transport caused by inappropriate handling.

We therefore ask you to examine the packaging and, if applicable, the inverter immediately upon receipt. If the packaging is damaged the inverter has to be checked. Please report damage without delay to the transport company.

Operating Instructions

Photovoltaic Inverters PAC/ PAC-S



7 Error diagnostics and correction

Should the inverter switch off due to failure, the background of the display starts to blink. At the same time the relay for alarm reporting locks and thus triggers the connected alarming functions.

For quick troubleshooting the following procedure we recommend:

At first the PV generator connection as well as the mains connection should be examined with regard to flawless connection to PAC inverter. For this purpose the safety instructions as mentioned in this document are to be observed. Please watch the display and note down possible error reports.

The following faults may occur and should be treated as follows:

Error	Cause	Explanation / Correction
No display	No mains voltage or error of hardware in the voltage supply	Please check mains voltage (fuses) If mains voltage is existent there is a defect in the voltage supply of the inverter. Please contact your installer.
No feeding	PV generator voltage is too low	Due to insufficient irradiation or at night PV generator voltage can sink below the minimum target value- inverter changes to energy saving mode. When the sun shines inverter starts feeding again independently.
No feeding	Fault peaks in the AC electricity network	Due to fault peaks from the electricity network that exceed the legally admissible limits there may be short shutdown of the inverter by the integrated mains monitoring. Possibly the adjusted mains limit values (voltage and frequency) should be examined and corrected by the installer.

Error	Cause	Explanation / Korrektion
No Signal via RS 485 interface	Wrong address in the service menu	In the service menu (installer) address of inverter can be adjusted. The first unit in a row has the address „01“, the second 2. „02“ etc. Please check this adjustment and correct it if necessary. On the last inverter in a row the three interface jumpers between CAN and RS 485 plug are to be plugged to connection on the main board (horizontally).
Mains fuse is triggered.	Hardware defect of inverter, stroke of lightning	Mains fuse is triggered immediately when the inverter switches to feeding operation. In this case there is a defect of the hardware of the inverter. Please contact your solarteuer.
Daily energy yield is not exactly identical with the yield of your energy supply company	Tolerances of the measuring elements in the inverter	Due to the tolerance the values shown on the display may deviate up to 10% from values of the export meter of your energy supply company.

Should it not be possible to provide elimination of the error with the help of measures described in these instructions please contact your PV installer or contact our customer service department directly.

To make sure that our service department can react quickly and in the right way information mentioned below is indispensable:

Information concerning the inverter

- Serial number of the unit
- Type of inverter
- Short description of error
- Is the error repeatable?
- Does error occur sporadically?

if possible:

Information to the PV generator

- Module type, manufacturer
- Number of modules in a row
- Number of poles
- Generator capacity

Operating Instructions

Photovoltaic Inverters PAC/ PAC-S



7.1 Service

During the development phase we attached great importance to quality and a long life cycle of the inverter. More than 15 years of experience in the field of power electronics and automation are the basis of this philosophy.

- Despite all the measures we take to assure high quality there may be failures in exceptional cases. In these cases you will get maximum possible support from OELMAIER Technology GmbH: Please contact our service department directly.

Telephone: 01804/ 131415 (20 ct./ call – as per 01/ 2008)

Mail: service@oelmaier-technology.de

www.oelmaier-technology.de

Oelmaier Technology GmbH

Kolpingstr. 2

88416 Ochsenhausen, Germany

7.2 Glossary

Derating	Limitation of performance to protect the inverter against overheating
EMI	electromagnetic interference
MSD	Mains Monitoring Device.
DC-OFF switch	DC disconnect switch, disconnects lines from PV generator to inverter and thus interrupts the DC voltage supply
IGBT	Insulated-Gate Bipolar Transistor (almost current-free activation, good transmissivity, high reverse voltage and robustness)
MC plug	„Multi contact plug“, DC connection for PV plants
MPP	Via the so-called MPP tracking the inverter takes the maximum possible output from the generator. MPP stands for „Maximum-Power-Point“.
PV module	Solar module, photovoltaic module; the PV module transforms sunlight into electric direct current
PV generator	The entire area of PV modules that are interconnected electrically